

THE NEXT GENERATION OF OIL FILTRATION



GENERATION2
FILTRATION™

LP SERIES

*For Diesel Engines &
Low Pressure Applications*



OIL DOES NOT WEAR OUT... IT BECOMES CONTAMINATED

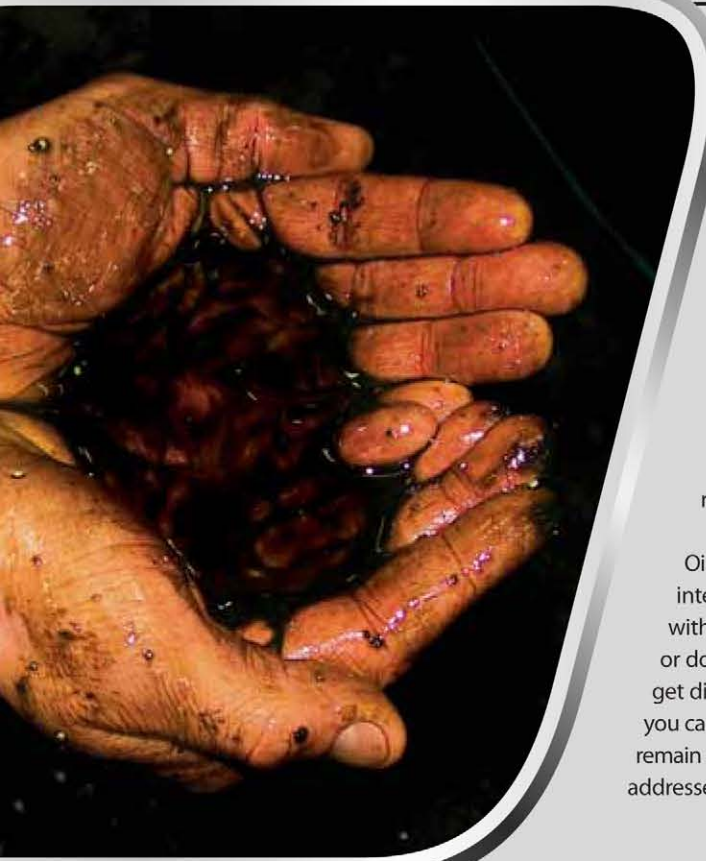

You change your oil, not because you want to, but because you have to. Engines operate in a range of different environments, and are subjected to different work loads, creating equally diverse rates of contamination. Therefore, engine manufacturers provide only 'recommended' oil change intervals.

With the availability of affordable oil analysis, the philosophy of changing the oil in a prescribed 'recommended' interval, has changed in recent years. Oil sample analysis is playing a large role in 'preventative maintenance' programs, allowing you to observe contamination levels, oil condition, and wear trends in your engine. These patterns can aid in identifying engine problems before they get out of hand. More importantly, oil sample analysis enables you to monitor the health of the additive package and contamination levels in the oil. With improved filtration, customers are able to safely maximize oil change intervals while achieving reduced engine wear, helping to reduce costs and environmental impact.

Oil does not wear out, it just gets dirty. Why is it the OEM recommended oil change interval is 250 hours on an engine with 70 liters of oil, while the exact same engine with a 140 liter oil reservoir has a recommended oil change interval of 500 hours, or double the time? With twice the volume of oil, it would take twice as long to get dirty. Oil needs to be changed when it becomes contaminated. The cleaner you can keep oil, the longer you can go between changes. If acidity levels in the oil remain low, you can dramatically prolong engine oil. Generation 2 Filtration™ (G2F) addresses both these concerns.

The Next Generation of Filtration

You need more than a standard oil and filter to extend engine life and time between oil changes. Particularly with the post 2006 engines having greater emission standards and while operating at higher temperatures, with much higher rates of contaminations. Standard oil filters are 'full-flow', meaning they filter 'all' the oil that enters the fine tolerances of the engine in a single pass. These filters are generally rated at 25 microns and are designed to pass high volumes of oil at high flow rates, limiting their ability to remove high volumes of 'ultra-fine' particles 1-15 microns in size (such as soot/carbon). These ultra-fine particles account for the majority of contamination associated with engine wear. In addition, full-flow filters do not efficiently remove the water produced in the combustion process. This causes the formation of acids in the oil, accelerating the depletion of additives, and increases corrosive action within the engine. Full flow filters alone cannot keep oil constantly clean, reduce engine wear or prolong oil.

Generation 2™ 'by-pass' filtration has the ability to polish small volumes of oil at slow flow rates, down to 1 micron, through the precision wound multi-ply 'axial-flow' cellulose element. This removes ultra-fine contamination and water normally missed by standard full-flow filters. With 4 stages of filtration, Generation 2™ elements are designed to meet the contamination levels associated with the new generation of engines equipped with sophisticated emission control hardware, including all types of Exhaust Gas Recirculator's (EGR's), diesel particulate filters (DPF) and ACERT technology. With the G2F's ability to work efficiently in these highly contaminated engines, G2F elements have an added advantage when installed on pre-2007 engines.



HOW TO REMOVE CONTAMINANTS AND KEEP OIL CLEAN

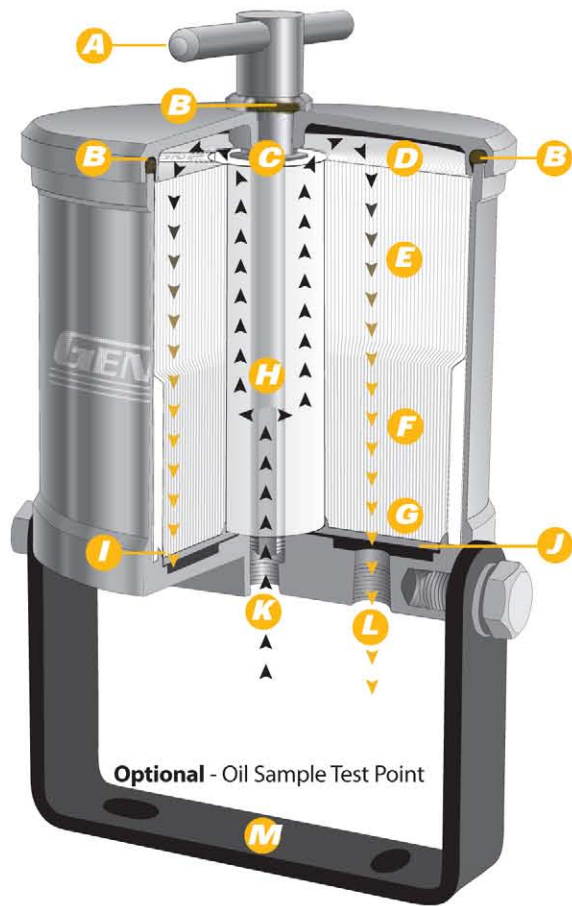

How It Works

The oil, under pressure, enters the bottom of the unit, moves up the centre core of the G2F element, before passing down through the 4-stages of micro-depth filtration. The oil is polished down to 1 micron, then discharged from the bottom of the unit, and returned to the oil reservoir. The G2F element should be changed at regular intervals, determined by the level of contamination produced by the engine and the environment it is operating in. The oil is to be changed depending upon the customer's targeted oil drain interval. Oil sample analysis is recommended to monitor extended oil drain intervals.

- A T-handle** - permits easy lid removal and element replacement
- B O-Ring**
- C Lid Ejection System** - automatically separates the lid from the canister
- D Stage 1 - Surface Filtration**
- E Stage 2 - Depth Filtration**
- F Stage 3 - Pressured Micro-Depth Filtration**
- G Stage 4 - Migrating Particle Filtration**
- H Oil Spike Suppressor**
- I Machine Sealed Edges**
- J Element Support Grill**
- K Inlet Pressure Port**
- L Outlet Drain Port**
- M Universal Mounting Bracket**

The G2F Element - The Secret to our Success

The G2F elements remove virtually everything from the oil with the exception of the additive package. By passing oil through the dense precision wound multi-ply 'axial-flow' cellulose element, the housing and the element are designed to exceed the demands of today's environmentally friendly engines.

- A Fabric Band** - element extraction strap, for easy removal
- B Course Sleeve** - protects upper stage of element
- C Crimped Outer Shell** - creates a dense micro filter media
- D Inner Core**
- E Non-Woven Filter Disc**
- F Standard Crepe Filter Paper**
- G Cross Crepe Filter Paper**

Healthy Oil - No Problem

Generation 2™ elements remove water at 99.97% from oil, dramatically decreasing the formation of acids, diminishing the accelerated depletion of additives, keeping the Total Base Number (TBN) at a high level. By removing ultra-fine particles down to 1 micron as they enter the oil, there is significantly less of a burden placed on the additives with less dirt to suspend, dramatically reducing mechanical wear while safely extending the oil change interval.

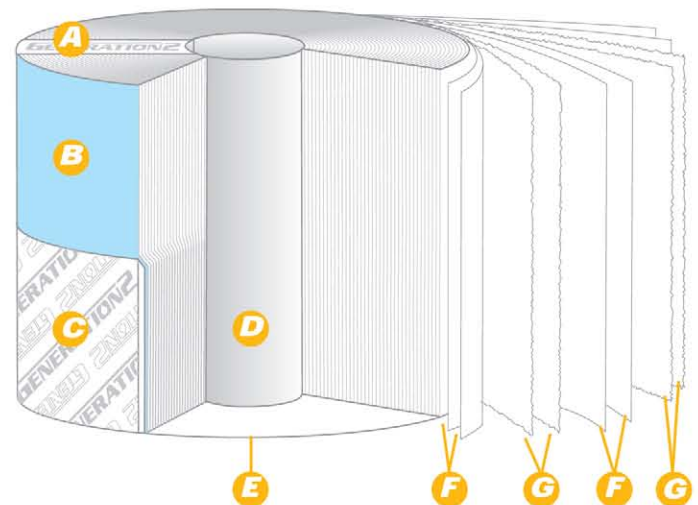

PROLONGING OIL WITH OPERATIONAL SAFETY

Contaminated Oil

Contaminated oil increases acid formation, particle build-up, varnish deposits, sludge deposits, acid pitting, corrosion, increased mechanical wear, accelerated viscosity breakdown, overheating, water contamination, poor oil circulation, oxidation and rapid additive depletion. G2F solves all these problems.

Acid Formation

- A Typical Filter** - The need for constant neutralization of acids formed in the engine is the major factor for TBN breakdown
- B Generation 2™** - Generation 2's ability to constantly remove water creates a virtually acid free engine significantly reducing the breakdown of the additives, minimizing corrosive action, and dramatically reducing the need to change the oil

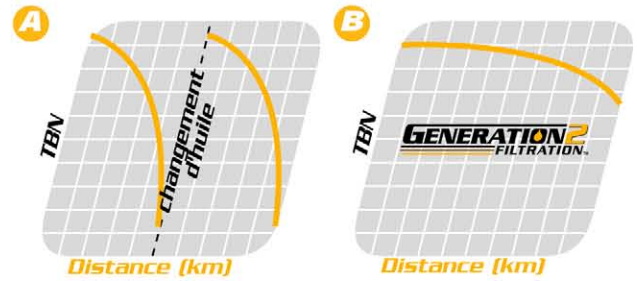

Partide Build-up

- C Typical Filter** - The constant build-up of fine particles held in suspension by the additives creates the need for regular oil changes.
- D Generation 2™** - The constant cleaning action prevents any particle build-up and creates a much cleaner engine, dramatically reducing oil changes.

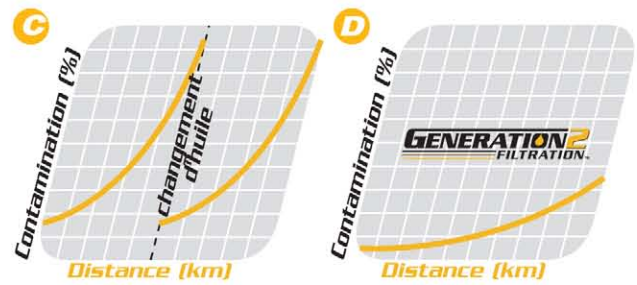

Simple to Install, Convenient to Change

Being a 'by-pass' filter, G2F can be installed on virtually any engine. Oil supply can be obtained from a pressure point along the oil gallery, oil pressure switch, or oil filter head. Once filtered, the polished oil is returned to the reservoir. Since G2F polishes oil at a very slow flow rate, installation of the system will in no way impede the operation of the engine or affect oil flow or pressure. It does not replace the conventional full-flow filtration system - it enhances and works in conjunction with it. As long as the engine is running, the G2F element will remove contamination and water missed by standard full-flow filters, dramatically prolonging the additive package and the oil with operational safety.



REDUCE CONTAMINATION, IMPROVE RELIABILITY AND ASSET MANAGEMENT

A Proactive Approach to Maintenance

The new approach to maintenance replaces the 'failure reactive' philosophy with 'failure proactive' by implementing corrective measures to avoid problems you will eventually encounter. G2F is a low cost 'Proactive' maintenance asset management tool. It lowers long-term maintenance costs, while providing short-term savings on oil, standard filters, downtime, and waste oil. This offers a relatively quick return on the capital investment. Some common problems are identified below by the condition of the G2F element .

- A Normal Element**- Changed at proper interval, element removed high concentrations of soot/carbon, indicating normal engine wear.
- B Metal Dust Particles Present** - Indicating engine overload. Wear is taking place in metal component. Investigate source immediately.
- C Soot/Carbon Overload** - Higher than normal levels accumulated indicating possible overheating, engine overload, coolant system malfunction, or due to extreme element extension intervals.
- D Fuel Dilution** - Element will become dry and turn grey in color, indicating fuel is present in the oil.
- E Coolant Leak** - Element is cracked, spongy, and shrunken, indicating water is present in the oil.



Benefits

There are many benefits associated with using G2F that helps improve your bottom line and lessen your environmental impact.

- ◆ Prolongs oil with operation safety
- ◆ Minimizes engine wear and prolongs component life
- ◆ Reduces new-unused oil and full-flow filter purchases
- ◆ Reduces waste oil
- ◆ Reduces waste oil disposal costs
- ◆ Reduces downtime for oil maintenance
- ◆ Minimizes the transfer and collection of waste oil
- ◆ Detects coolant leaks
- ◆ Detects fuel dilution
- ◆ Improves oil circulation
- ◆ Reduces downtime and replacement parts

"We do not inherit the earth from our parents, we borrow it from our children" - Aldo Leopold



Helping the Environment

The earth has a limited supply of non-renewable resources that are depleting at alarming rates. With added pressure on industry to reduce environmental impact and the implementation of ISO 14001, G2F helps industry do their part to reduce waste oil and protect the environment for future generations.

FOR A RANGE OF DIESEL ENGINE APPLICATIONS...AND MORE



Diesel engines play an important role, particularly in the primary and secondary industries including mining, construction, fishery, transportation, agriculture, forestry, oil and gas, power generation, and waste management to name a few. Some direct applications would include:

- ◆ Heavy Duty Trucks
 - ◆ Light Trucks
 - ◆ Heavy Equipment
 - ◆ Power Generators
 - ◆ Marine Engines
 - ◆ Locomotives
 - ◆ Buses
- ◆ Rock Trucks
 - ◆ Tractors
 - ◆ Loaders
 - ◆ Excavators
 - ◆ Forklifts
 - ◆ Recreational Vehicles
 - ◆ Cranes

In addition to engines, Generation 2 Filtration™ Systems are designed to filter mineral, synthetic, and vegetable oils, found in a wide range of applications including:

- ◆ Hydraulics
 - ◆ Transmissions
 - ◆ Water Glycol
 - ◆ Compressors
 - ◆ Gear Boxes
- ◆ Industrial Lube Systems
 - ◆ Turbines
 - ◆ Thermal Oil
 - ◆ Industrial Oils

The LP Series for diesel engines and low pressure applications come in a range of sizes.

Model	G2F-LP150	G2F-LP250	G2F-LP350	G2F-LP450	G2F-DLP250	G2F-DLP350	G2F-DLP450
Oil Pan Capacity	15 ℓ * 3.96 gal	45 ℓ 11.89 gal	90 ℓ 23.78 gal	130 ℓ 34.34 gal	45 ℓ 11.89 gal	90 ℓ 23.78 gal	130 ℓ 34.34 gal
Flow Rates	1.5 ℓ/min * 0.40 gal/min	2.2 ℓ/min 0.58 gal/min	3.8 ℓ/min 1 gal/min	6.7 ℓ/min 1.77 gal/min	2 ℓ/min 0.53 gal/min	3.2 ℓ/min 0.85 gal/min	5.8 ℓ/min 1.53 gal/min

* gal = US gallon

WARRANTY: Limited life-time warranty to the original purchaser for defects in workmanship and materials of the filter canister only. Warranty is not transferable. Engine hose, adapters, and reusable ends are warranted by the original manufacturer. The use of a Generation 2 Filtration™ system does not affect original engine manufacture warranty. As technical advancements take place, product specifications may be subject to change. L.B.S. Lubrication Units Inc. (est. 1995) is the global distributor of Generation 2 Filtration™ line of products.



L.B.S. LUBRICATION UNITS INC.

45 O'Connor Street, Suite 1150

Ottawa, Ontario

Canada K1P 1A4

Head Office:

Tel: (613) 755-6010

Fax: (613) 248-4845

Toll Free: 1-800-960-3848 (North America)

Email: info@generation2filtration.com

www.generation2filtration.com

